

AQRP Monthly Technical Report

PROJECT TITLE	Sources of Organic Particulate Matter in Houston: Evidence from DISCOVER-AQ data Modeling and Experiments	PROJECT #	14-024
PROJECT PARTICIPANTS	Lea Hildebrandt Ruiz and Ying Xu (The University of Texas at Austin) Greg Yarwood Bonyoung Koo (ENVIRON) Gookyoung Heo (University of California, Riverside)	DATE SUBMITTED	8/8/2014
REPORTING PERIOD	From: July 1, 2015 To: July 31, 2015	REPORT #	2

A Financial Status Report (FSR) and Invoice will be submitted separately from each of the Project Participants reflecting charges for this Reporting Period. I understand that the FSR and Invoice are due to the AQRP by the 15th of the month following the reporting period shown above.

Detailed Accomplishments by Task

Task 1: Inventory Analysis

We have conducted a literature review to identify the most recent IVOC emission estimates. IVOCs are typically missing from traditional emission inventories because they are too volatile to be included in primary PM and too difficult to speciate with standard GC methods to be included in VOC. Robinson et al. (2007) estimated IVOC emissions by scaling from existing POA emissions. A limitation of this approach is that the ratio of IVOC to POA emissions would depend on gas-particle partitioning of POA at the measurement condition. Pye and Seinfeld (2010) instead scaled IVOC emissions to naphthalene which is often quantified as a component of VOC. A limitation of this approach is that IVOC emissions are assumed to have the same spatial and temporal distribution as naphthalene.

Recently, Jathar et al. (2014) analyzed published smog chamber data for on-road gasoline and diesel vehicle emissions (from Gordon et al., 2014a,b; May et al., 2014) and biomass burning emissions (from Hennigan et al., 2011) and investigated SOA formation from unspciated non-methane organic gas (NMOG) emissions. Table 1 shows their estimates of source-specific unspciated fractions of NMOG (i.e., approximate IVOC-to-NMOG ratios). The definition of NMOG is more inclusive than VOC because NMOG includes compounds like ethane and acetone that are excluded from the definition of VOC because they have low tendency to form ozone. When VOC emissions are processed for use in photochemical modeling the chemical speciation step reconstructs NMOG from VOC by using speciation profiles from EPA's SPECIATE database or a similar source of information.

Table 1. Estimated unspciated NMOG fractions (Jathar et al., 2014).

Source	Unspciated fraction of NMOG
Gasoline vehicles ^a	0.25
Diesel vehicles ^{a,b}	0.20
Biomass burning	0.20
Wood burning ^c	0.07

^a Jathar et al. (2014) assumed the same unspciated fractions for both on- and off-road engines.

^b Based on the Schauer et al. (1999) and Siegl et al. (1999) data.

^c Based on the Schauer et al. (2001) and McDonald et al. (2000) data.

Jathar et al. (2014) noted that speciated NMOG emissions, which include traditional SOA precursors such as toluene, should be adjusted because the speciation profiles employed in the current inventory development process (e.g., from SPECIATE) compute weight fractions relative to the sum of the speciated NMOG rather than total NMOG in order to represent all of the NMOG mass as identified compounds.

The reaction rates and SOA mass yields of the estimated IVOC precursors were represented by n-alkane surrogate species: n-pentadecane (C15) for diesel vehicles and biomass burning; n-tridecane (C13) for gasoline vehicles (Jathar et al., 2014). Use of other surrogate species has been also reported: Pye and Pouliot (2012) modeled SOA formation from IVOC emissions using n-dodecane (C12) and naphthalene. For our modeling, we will use the IVOC-to-NMOG ratios in Table 1 to estimate IVOC emissions from mobile sources and biomass burning and employ the same surrogate species as chosen by Jathar et al. (2014).

We have reviewed speciated point source emissions data for Houston (specifically we reviewed data for Harris County) provided by TCEQ for 2012 from the STARS database. The review identified two potential types of point source IVOC emissions. First, many facilities report emissions hydrocarbon mixtures, e.g. distillates, as total emissions. The un-speciated mixture must be speciated to specific NMOG compounds using speciation profiles in a process that may under count IVOC components as discussed above. Mixtures of this type include petroleum distillates (226 tons/year), mineral spirits (123 tons/year), distillate (103 tons/year), lubricating oil (52 tons/year), vacuum bottoms (37 tons/year) mineral oil (33 tons/year) and reformat (21 tons/year). Second, emissions are reported for a number of high boiling point compounds including 1,4-dichlorobenzene (7.3 tons/year) and several oxygenated hydrocarbons (diacetone alcohol, 4.7 tons/year; butyl carbitol, 3.5 tons/year; maelic acid, 3.5 tons/year). These compounds all fit within the definition of VOC because they have boiling points less than 250 C but their SOA forming potential should be assessed.

Task 2: Environmental Chamber Experiments

We have finalized the design for the thermodenuder and the heated injector, which will be needed for the chamber experiments. The thermodenuder will be built by Swagelok; the heated injector will most likely be built by a machine shop at UT Austin.

Figure 1 shows a drawing of the thermodenuder. It consists of 1 inch diameter stainless steel tubing connected by three Swagelok fitting / reducing unions. The temperature inside of the thermodenuder will be measured with a thermocouple in three locations (the locations of the fittings). The stainless steel tubing and the fittings will be wrapped with heating tape and controlled using temperature controllers (purchased separately).

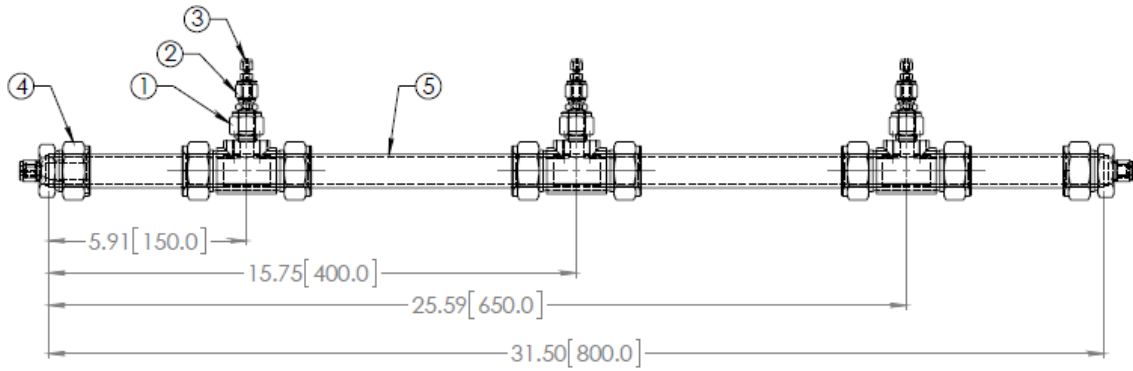

Figure 1. Drawing of thermodenuder to be built by Swagelok

Figure 2 shows a preliminary drawing of the heated injector, which will be built from stainless steel. The entire heated injector will be inserted into the environmental chamber. The solid SVOC will be placed on the opening. The heater cartridge will be placed inside of the heated injector. The cartridge can reach temperatures up to 300°C and will cause the IVOC to sublime. Clean air will pass over the opening and introduce the sublimated IVOC into the chamber.

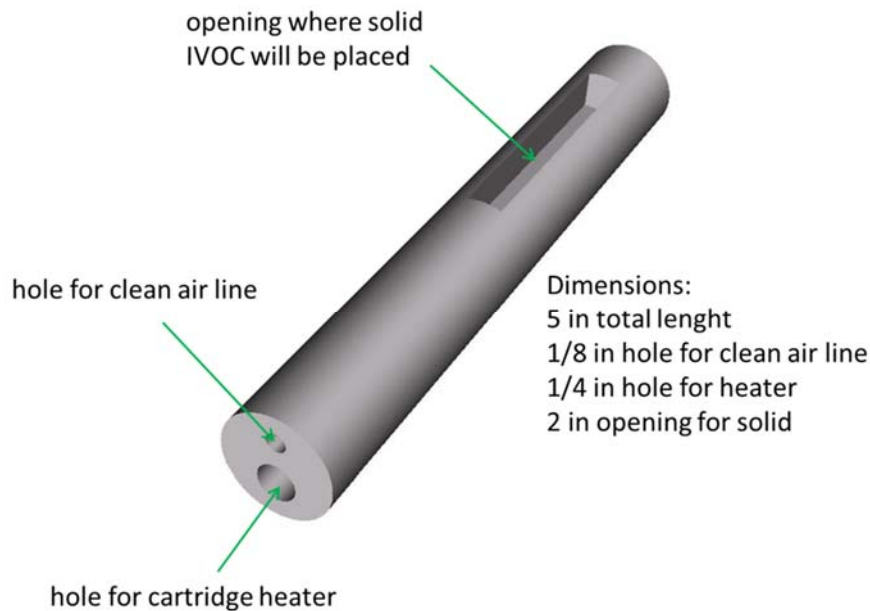

Figure 2. Preliminary drawing of heated injector to be built by a machine shop at UT Austin

Preliminary Analysis

Data Collected

Identify Problems or Issues Encountered and Proposed Solutions or Adjustments

None to date

Goals and Anticipated Issues for the Succeeding Reporting Period

Task 1: Propose a method for estimating IVOC emissions from hydrocarbon mixtures, e.g. distillates, reported in TCEQ's point source emissions inventory based on the STARS database. Assess whether emissions of compounds with high boiling points reported in the STARS database have sufficient SOA forming potential to be considered in this project.

Task 2: Have the body of the thermodenuder built by Swagelok. Order heating tape and temperature controllers and set them up to heat the thermodenuder. Have the heated injector built and test it with one IVOC. Make a preliminary list of IVOCs to be studied in chamber experiments now that the literature reviews have been completed.

Detailed Analysis of the Progress of the Task Order to Date

Progress has been as expected to date.

References

- Gordon, T.D., Presto, A.A., Nguyen, N.T., Robertson, W.H., Na, K., Sahay, K.N., Zhang, M., Maddox, C., Rieger, P., Chattopadhyay, S., Maldonado, H., Maricq, M.M., Robinson, A.L., 2014a. Secondary organic aerosol production from diesel vehicle exhaust: impact of aftertreatment, fuel chemistry and driving cycle. *Atmos. Chem. Phys.*, 14, 4643-4659.
- Gordon, T.D., Presto, A.A., May, A.A., Nguyen, N.T., Lipsky, E.M., Donahue, N.M., Gutierrez, A., Zhang, M., Maddox, C., Rieger, P., Chattopadhyay, S., Maldonado, H., Maricq, M.M., Robinson, A.L., 2014b. Secondary organic aerosol formation exceeds primary particulate matter emissions for light-duty gasoline vehicles. *Atmos. Chem. Phys.*, 14, 4661-4678.
- Hennigan, C.J., Miracolo, M.A., Engelhart, G.J., May, A.A., Presto, A.A., Lee, T., Sullivan, A.P., McMeeking, G.R., Coe, H., Wold, C.E., Hao, W.-M., Gilman, J.B., Kuster, W.C., de Gouw, J., Schichtel, B.A., Collett Jr., J.L., Kreidenweis, S.M., Robinson, A.L., 2011. Chemical and physical transformations of organic aerosol from the photo-oxidation of open biomass burning emissions in an environmental chamber. *Atmos. Chem. Phys.*, 11, 7669-7686.
- May, A.A., Nguyen, N.T., Presto, A.A., Gordon, T.D., Lipsky, E.M., Karve, M., Gutierrez, A., Robertson, W.H., Zhang, M., Brandowe, C., Chang, O., Chen, S., Cicero-Fernandez, P., Dinkins, L., Fuentes, M., Huang, S.-M., Ling, R., Long, J., Maddox, C., Massetti, J., McCauley, E., Miguel, A., Na, K., Ong, R., Pang, Y., Rieger, P., Sax, T., Truong, T., Vo, T., Chattopadhyay, S., Maldonado, H., Maricq, M.M., Robinson, A.L., 2014. Gas- and particle-phase primary emissions from in-use, on-road gasoline and diesel vehicles. *Atmos. Environ.*, 88, 247-260.
- McDonald, J.D., Zielinska, B., Fujita, E.M., Sagebiel, J.C., Chow, J.C., Watson, J.G., 2000. Fine particle and gaseous emission rates from residential wood combustion. *Environ. Sci. Technol.*, 34, 2080-2091.

Pye, H.O.T., Pouliot, G.A., 2012. Modeling the Role of Alkanes, Polycyclic Aromatic Hydrocarbons, and Their Oligomers in Secondary Organic Aerosol Formation. *Environ. Sci. Technol.*, 46, 6041-6047.

Pye, H.O.T., Seinfeld, J.H., 2010. A global perspective on aerosol from low-volatility organic compounds. *Atmos. Chem. Phys.*, 10, 4377-4401.

Robinson, A.L., Donahue, N.M., Shrivastava, M.K., Weitkamp, E.A., Sage, A.M., Grieshop, A.P., Lane, T.E., Pierce, J.R., Pandis, S.N., 2007. Rethinking organic aerosols: semivolatile emissions and photochemical aging. *Science*, 315, 1259-1262.

Schauer, J.J., Kleeman, M.J., Cass, G.R., Simoneit, B.R.T., 1999. Measurement of emissions from air pollution sources. 2. C1 through C30 organic compounds from medium duty diesel trucks. *Environ. Sci. Technol.*, 33, 1578-1587.

Schauer, J.J., Kleeman, M.J., Cass, G.R., Simoneit, B.R.T., 2001. Measurement of emissions from air pollution sources. 3. C1-C29 organic compounds from fireplace combustion of wood. *Environ. Sci. Technol.*, 35, 1716-1728.

Siegl, W.O., Hammerle, R.H., Herrmann, H.M., Wenclawiak, B.W., Luers-Jongen, B., 1999. Organic emissions profile for a light-duty diesel vehicle. *Atmos. Environ.*, 33, 797-805.

Submitted to AQRP by: Lea Hildebrandt Ruiz

Principal Investigator: Lea Hildebrandt Ruiz